

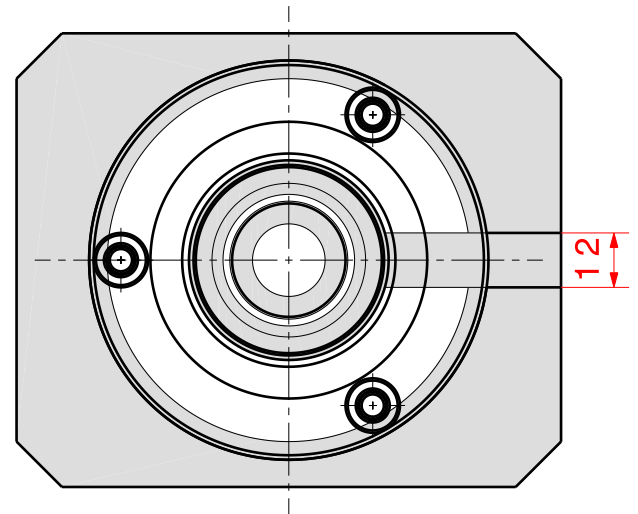

Schema per applicazione a singola cavità

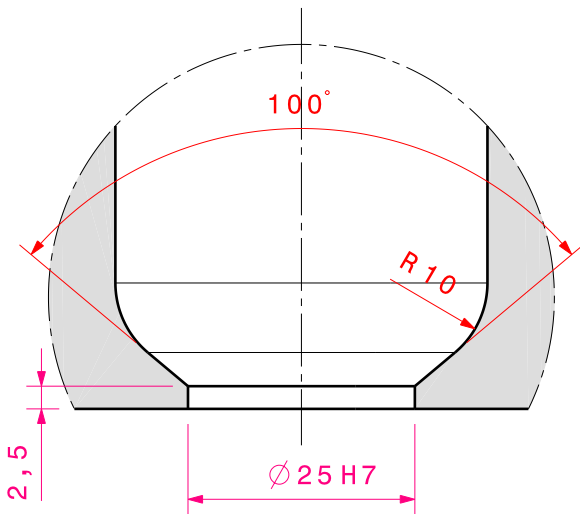
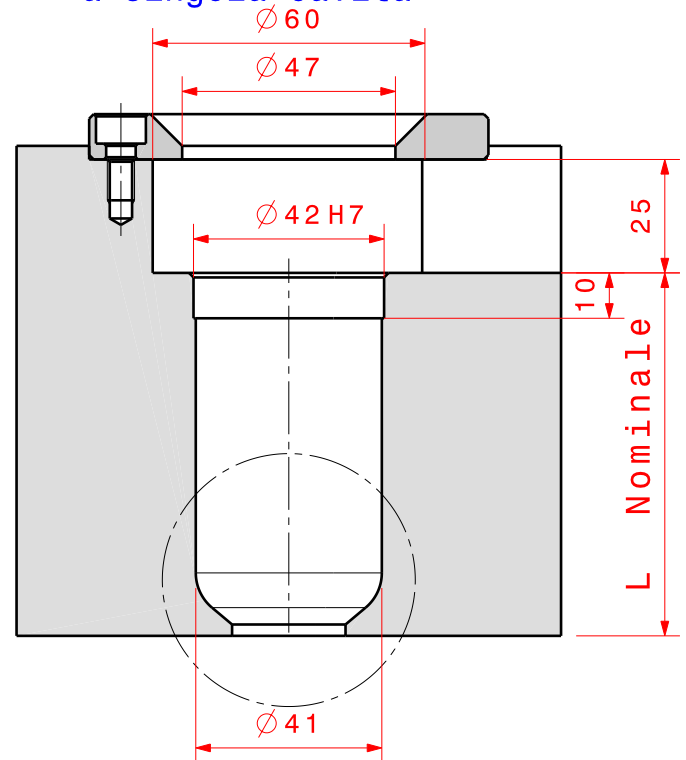
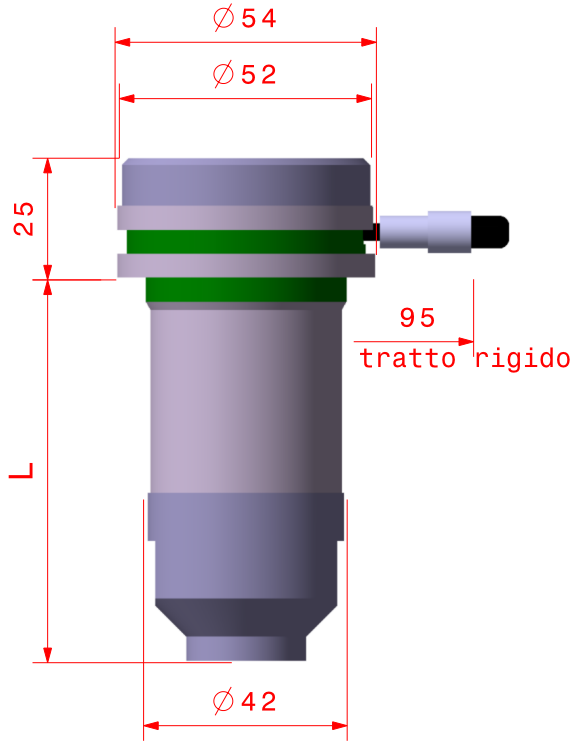

Codice Iniettore	L	Codice Stelo	Codice Bussola	Codice Puntale	Codice Boccola	Codice Resistenza	Codice Termocoppia
I 36055	55	S 30055	B 36055	P 31010	BC 31055	C 24016	C 15100
I 36065	65	S 30065	B 36065	P 31010	BC 31055	C 24018	C 15100
I 36080	80	S 30080	B 36080	P 31010	BC 31055	C 24020	C 15150
I 36100	100	S 30100	B 36100	P 31010	BC 31055	C 24022	C 15150
I 36125	125	S 30125	B 36125	P 31010	BC 31055	C 24024	C 15150
I 36150	150	S 30150	B 36150	P 31010	BC 31055	C 24026	C 15200
I 36200	200	S 30200	B 36200	P 31010	BC 31055	C 24038	C 15250

Peso massimo iniettabile	
Viscosità Grammi	
Bassa	2500
Media	1500
Alta	1000