

Schema per applicazione  
a singola cavità

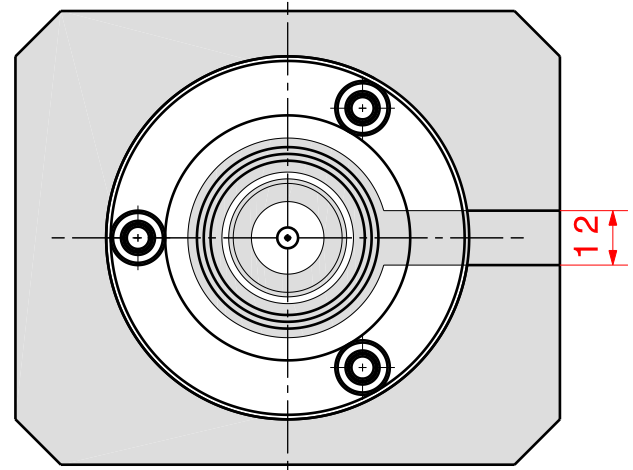
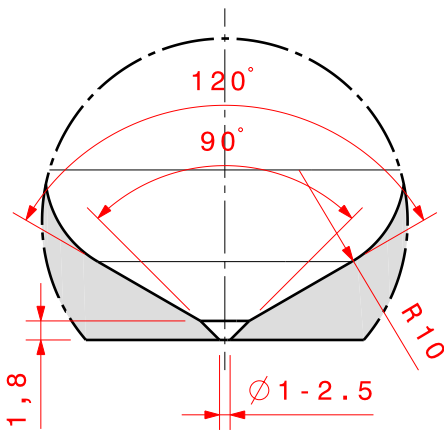
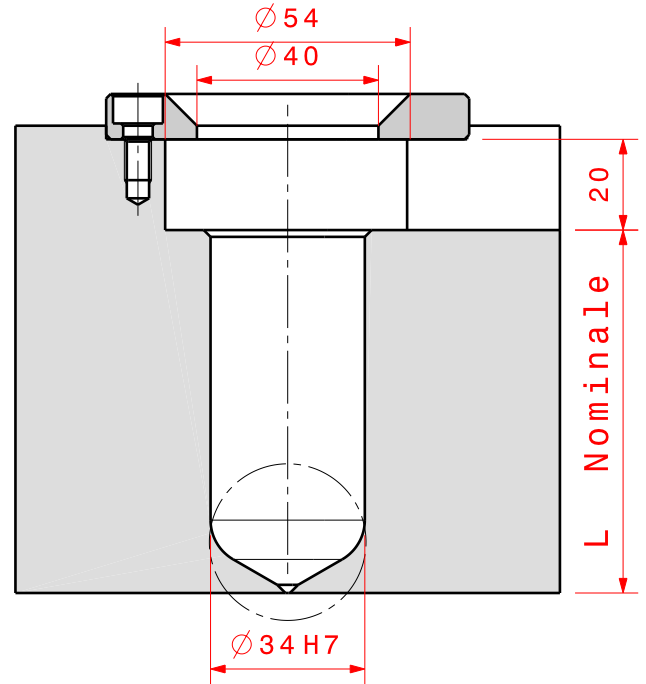
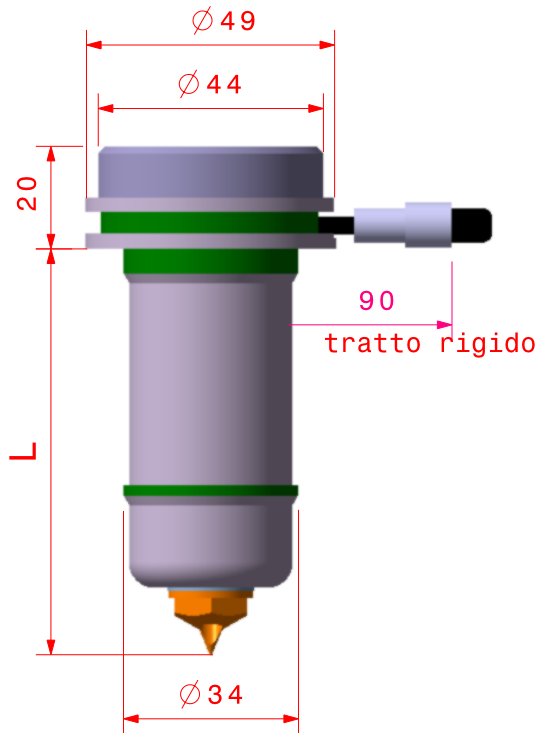

Codice Iniettore	L	Codice Stelo	Codice Bussola	Codice Puntale	Codice Resistenza	Codice Termocoppia	Peso massimo iniettabile
I 20035	35	S 20035	B 20035	P 20010	C 01835	C 15100	Viscosità Grammi
I 20045	45	S 20045	B 20045	P 20010	C 01845	C 15100	Bassa 400
I 20055	55	S 20055	B 20055	P 20010	C 01855	C 15100	Media 200
I 20065	65	S 20065	B 20065	P 20010	C 01865	C 15100	Alta 150
I 20080	80	S 20080	B 20080	P 20010	C 01870	C 15150	
I 20100	100	S 20100	B 20100	P 20010	C 01875	C 15150	
I 20125	125	S 20125	B 20125	P 20010	C 01880	C 15150	
I 20150	150	S 20150	B 20150	P 20010	C 01885	C 15200	