

Schema per applicazione
a singola cavità

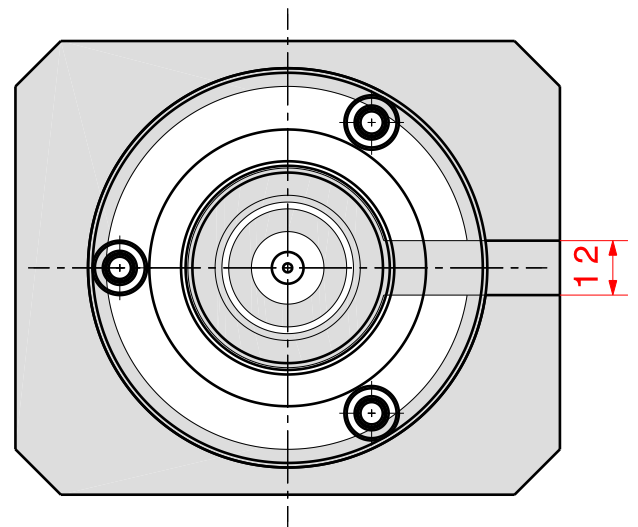
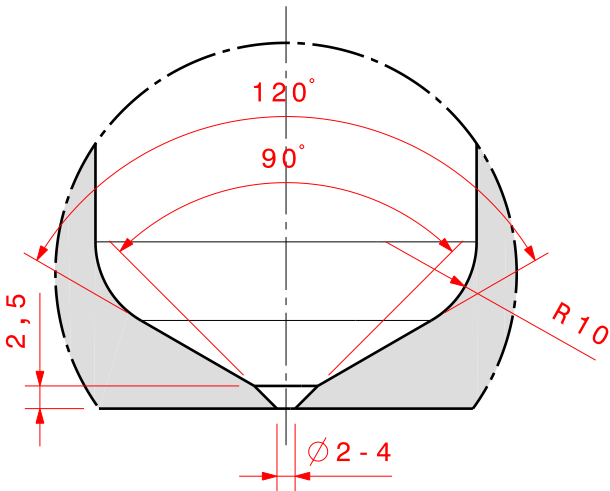
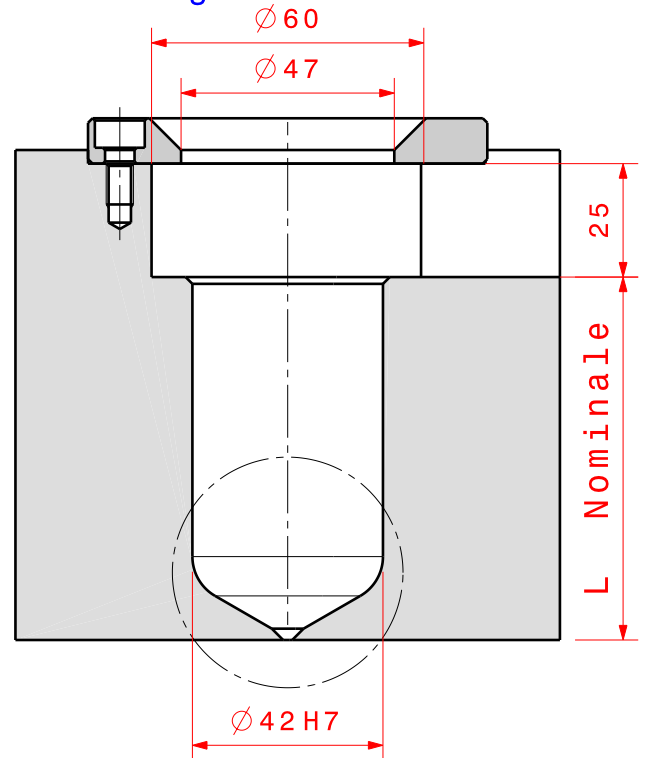
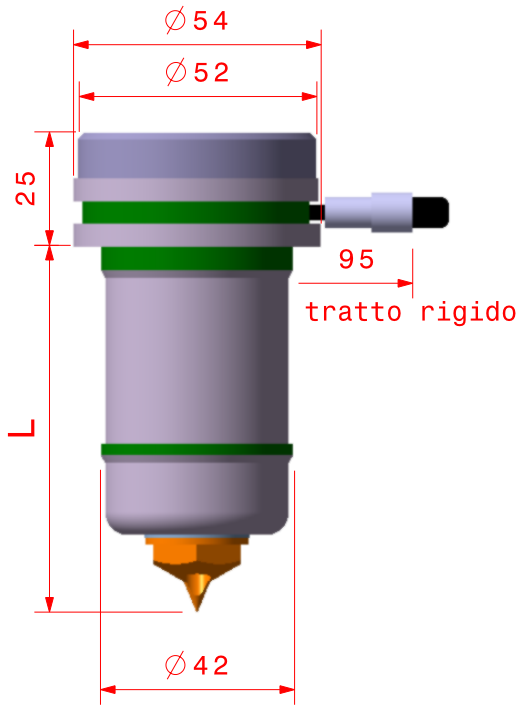

Codice Iniettore	L	Codice Stelo	Codice Bussola	Codice Puntale	Codice Resistenza	Codice Termocoppia	Peso massimo iniettabile
I 30055	55	S 30055	B 30055	P 30010	C 24016	C 15100	Viscosità Grammi
I 30065	65	S 30065	B 30065	P 30010	C 24018	C 15100	Bassa 2500
I 30080	80	S 30080	B 30080	P 30010	C 24020	C 15150	Media 1500
I 30100	100	S 30100	B 30100	P 30010	C 24022	C 15150	Alta 1000
I 30125	125	S 30125	B 30125	P 30010	C 24024	C 15150	
I 30150	150	S 30150	B 30150	P 30010	C 24026	C 15200	
I 30200	200	S 30200	B 30200	P 30010	C 24038	C 15250	